

TYPICAL HOLDDOWN INSTALLATION 3 **A**

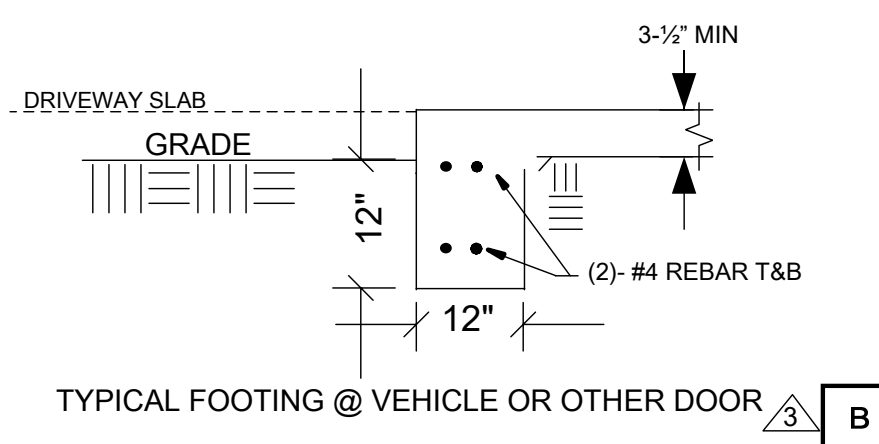

TYPICAL FOOTING @ VEHICLE OR OTHER DOOR 3 **B**

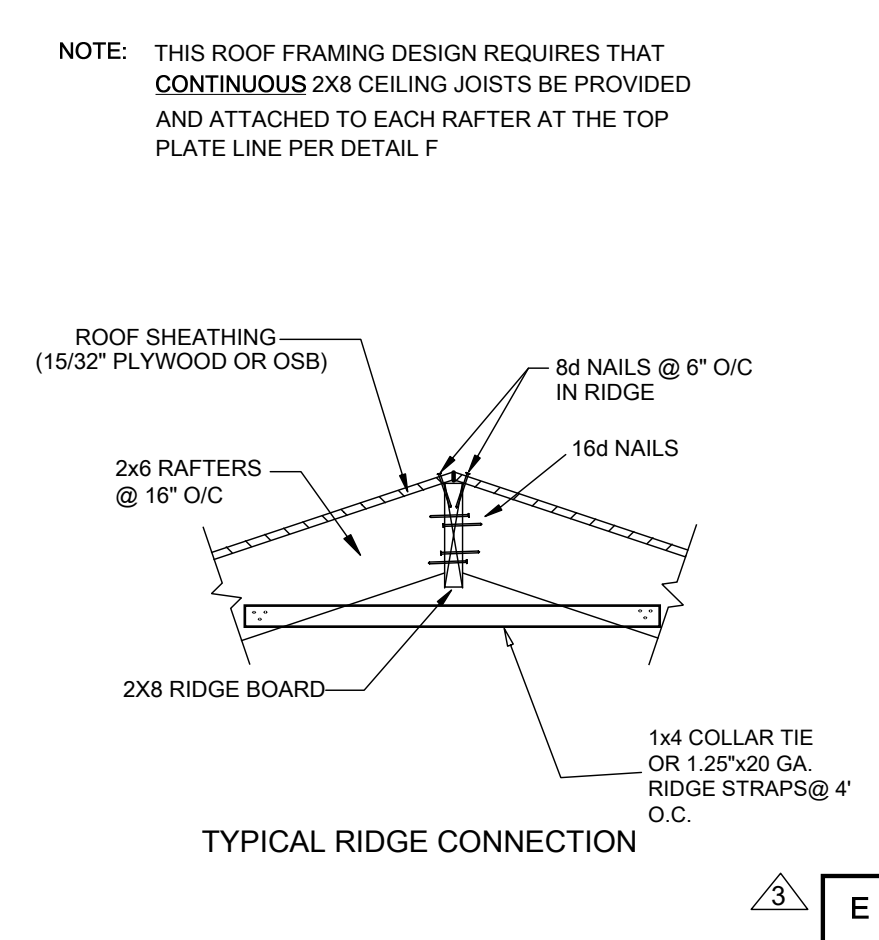

TYPICAL RIDGE CONNECTION 3 **E**

SEE NOTES ON SHEET 1 FOR ADDITIONAL INFORMATION.

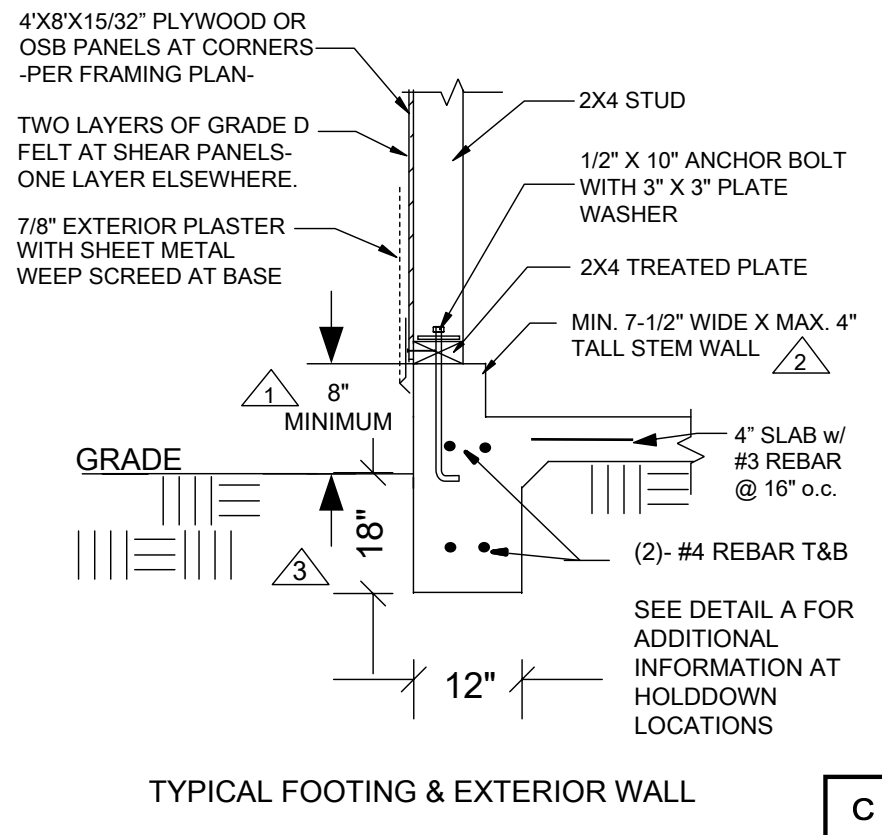

TYPICAL FOOTING & EXTERIOR WALL 2 **C**

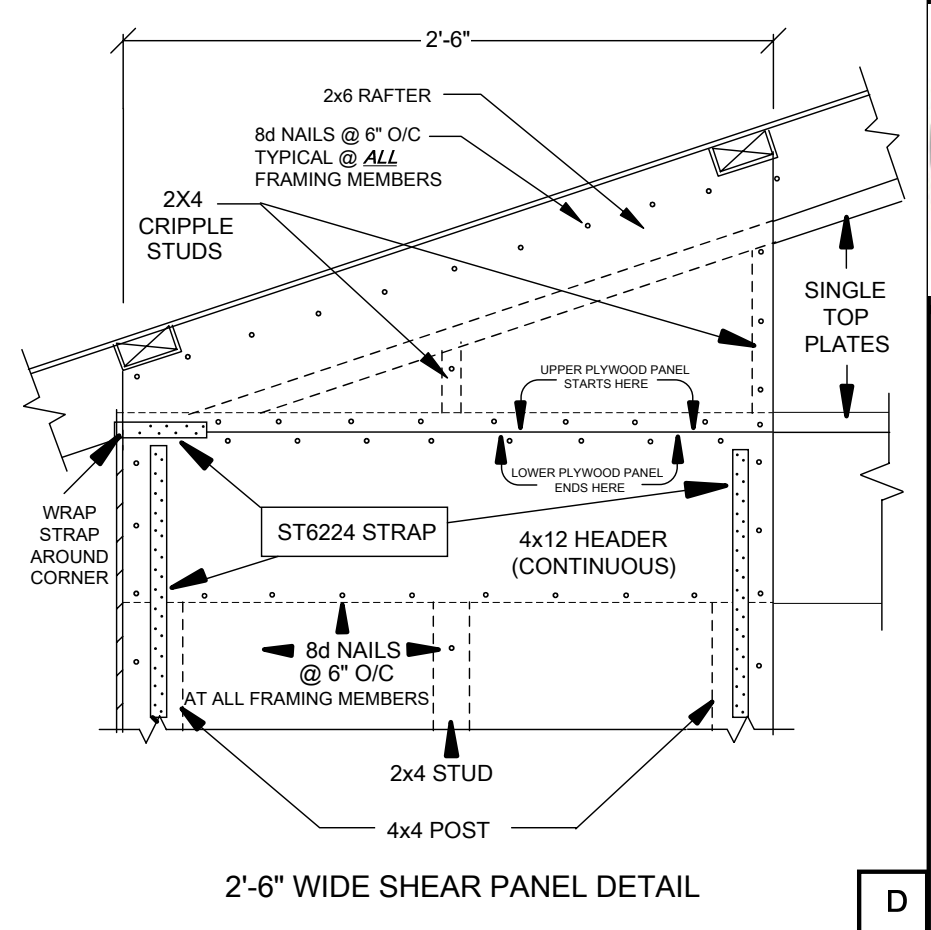

2'-6" WIDE SHEAR PANEL DETAIL **D**

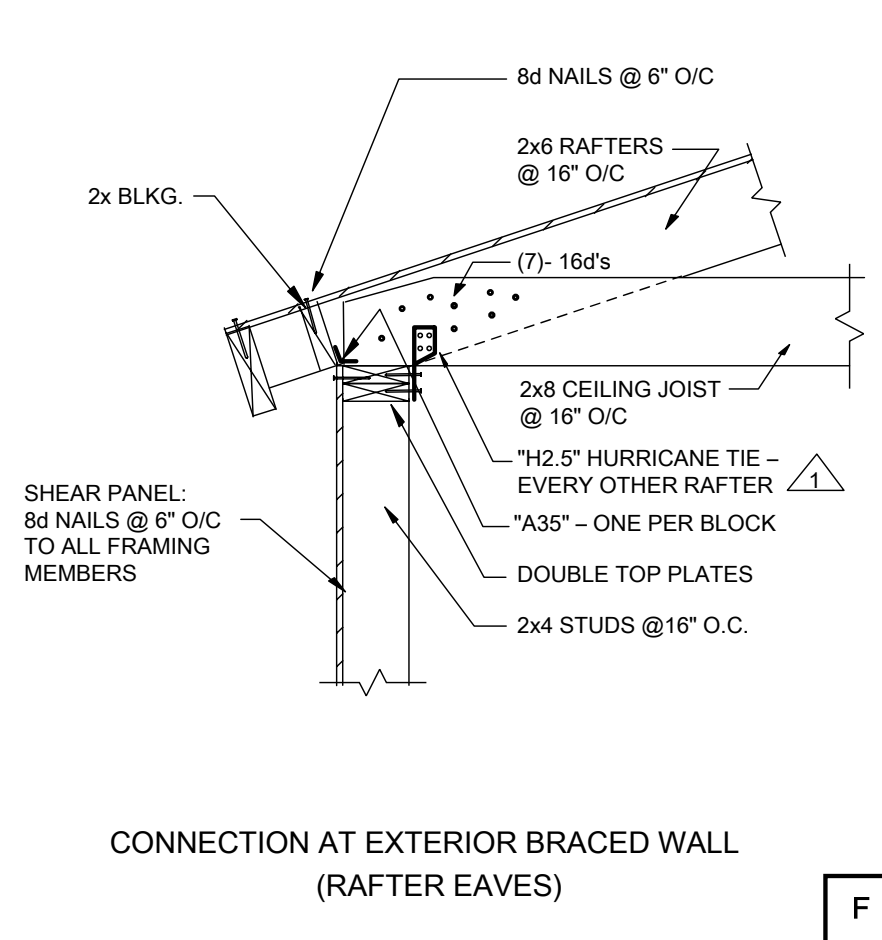

CONNECTION AT EXTERIOR BRACED WALL (RAFTER EAVES) 1 **F**

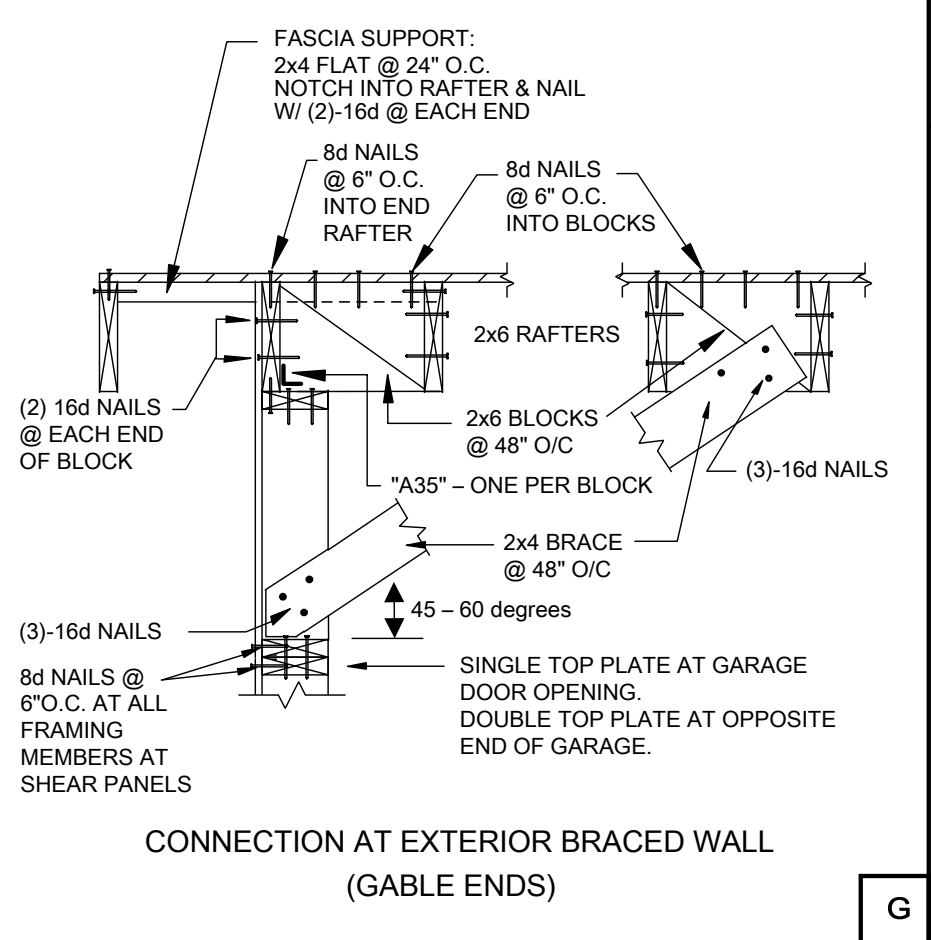

CONNECTION AT EXTERIOR BRACED WALL (GABLE ENDS) **G**



CITY OF KINGSBURG
 BUILDING & SAFETY DIVISION
 1401 DRAPER ST, KINGSBURG, CA 93631
 559-897-5328
 WWW.CITYOFKINGSBURG-CA.GOV

SCALE	NONE	
DRAWN	6/1/2007	
DATE		
REV.	DATE	APPR.
1	1/1/2023	CBC
2		
3		
4		
5		
G/BLDG/HANDOUTS/GARAGE2		
GARAGE		
DETAILS		
RGH-2.0		
SHEET		